

# Transport trolleys S-series

For load weights up to 48 metric tons

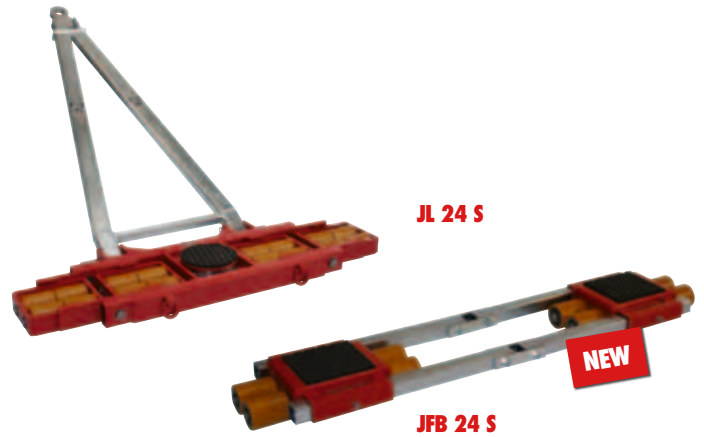

**Available with:**  
JUWATHan-coated steel castors

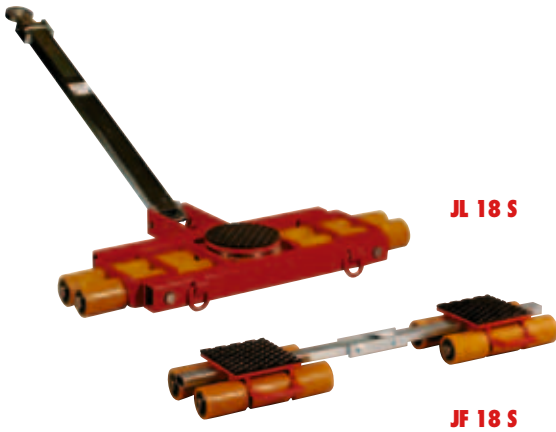

for any floors  
Order number 95 050 025-V

**Available with:**  
Steel castors



for insensitive floors  
Order number 95 050 026-S

## Advantages in detail

- Pivoting roller cassettes within the frame assure even pressure distribution across all rollers and across the floor. No need for complex and expensive hydraulic compensation system.
- Low height at only 125 mm / 4.9" with high capacity.

▶ Please refer to page 28-29 for additional roller information.

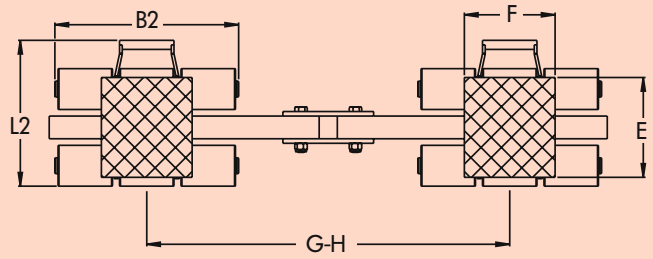
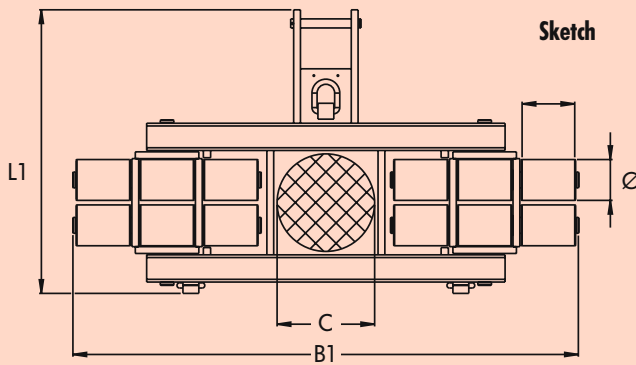

Type	Sketch	36 metric tons		48 metric tons		
		JL 18 S	JF 18 S	JL 24 S	JFB 24 S	
Load capacity	kg / lbs	18 000 / 39 600	18 000 / 39 600	24 000 / 52 800	24 000 / 52 800	
Number of castors	pcs	12	12	16	16	
Castor dimensions	Ø x l mm / in	90 x 120 / 3.5 x 4.7"	90 x 120 / 3.5 x 4.7"	90 x 120 / 3.5 x 4.7"	90 x 120 / 3.5 x 4.7"	
Fitting height	mm / in	125 / 4.9"	125 / 4.9"	125 / 4.9"	125 / 4.9"	
Supporting surface per cassette	E x F mm / in		220 x 200 / 8.6 x 7.8"		200 x 220 / 7.9 x 8.7"	
Cassette dimensions	L2 x B2 mm / in		260 x 410 / 10.2 x 16.1"		370 x 565 / 14.6 x 22.2"	
Connecting rod with joint	Length mm / in		1 230 / 48.4"		2 x 1 540 / 60.6"	
Cassettes adjustable from - to	G - H mm / in		420 - 1100 / 16.5 - 43.3"		700 - 1300 / 27.6 - 51.2"	
Supporting surface of turntable	Ø C mm / in		215 / 8.5"		215 / 8.5"	
Dimensions	L1 x B1 mm / in		600 x 1 120 / 23.6 x 44.1"		610 x 1 500 / 24 x 59"	
Handlebar with pulling eye	mm / in		1 230 / 48.4"		1 590 / 62.6"	
Weight JUWATHan Steel	kg - lbs		110 / 118 - 242 / 260		205 / 224 - 452 / 494	
Order-no. with JUWATHan coated castors			05 180 090-V	06 180 090-V	05 240 090-V	06 241 090-V
Order-no. with steel castors			05 180 090-S	06 180 090-S	05 240 090-S	06 241 090-S